



TR-500EX

Left hand steering

GENERAL DATA

CRANE CAPACITY	50,000 kg at 3.5 m
BOOM	4-section, 11.0 m – 35.0 m
DIMENSION	
Overall length	approx. 13,630 mm
Overall width	approx. 3,315 mm
Overall height	approx. 3,780 mm
MASS	
Gross vehicle mass	approx. 43,200 kg
-front axle	approx. 22,820 kg
-rear axle	approx. 20,380 kg
PERFORMANCE	
Max. travelling speed	computed 40 km/h
* Gradeability (tan θ)	computed 57 % (at 2.5 km/h)

*: Machine should be operated within the limit of engine crankcase design (30° : MMC 6D16-TLEA).

CRANE SPECIFICATIONS

MODEL

TR-500EX

CAPACITY

50,000 kg at 3.5 m

BOOM

4-section full power partially synchronized telescoping boom of hexagonal box construction with 5 sheaves at boom head. The synchronization system consists of 2 telescope cylinders, an extension cable and a retraction cable. Hydraulic cylinders fitted with holding valves.

Fully retracted length..... 11.0 m

Fully extended length..... 35.0 m

Extension speed..... 24.0 m in 153 s

JIB

2-staged swingaround boom extension. Dual offset (5°/30°) type. Box type top section telescopes from lattice type base section which stores alongside base boom section.

Single sheave at jib head.

Length 9.8 m and 17.1 m

SINGLE TOP (AUXILIARY BOOM SHEAVE)

Single sheave. Mounted to main boom head for single line work.

ELEVATION

By a double-acting hydraulic cylinder, fitted with holding valve.

Elevation speed - 1.5° to 80° in 68 s

TADANO LTD.

HOIST – Main winch

Variable speed type with grooved drum driven by hydraulic axial piston motor through winch speed reducer. Power load lowering and hoisting.

Equipped with automatic brake (Neutral brake) and counterbalance valve.

Controlled independently of auxiliary winch.

Single line pull.....52.9 kN {5,400 kgf}

Single line speed .. 140 m/min. (at the 4th layer)

Wire rope.....Spin-resistant type

Diameter × length..... 19 mm × 205 m

HOOK BLOCK – 50 ton capacity

5 sheaves, swivel type hook with safety latch.

HOIST – Auxiliary winch

Variable speed type with grooved drum driven by hydraulic axial piston motor through winch speed reducer. Power load lowering and hoisting.

Equipped with automatic brake (Neutral brake) and counterbalance valve.

Controlled independently of main winch.

Single line pull.....54.9 kN {5,600 kgf}

Single line speed .. 120 m/min. (at the 2nd layer)

Wire rope.....Spin-resistant type

Diameter × length..... 19 mm × 116 m

HOOK BLOCK – 5.6 ton capacity

Swivel hook with safety latch for single line use.

SWING

Hydraulic axial piston motor driven through planetary speed reducer. Continuous 360° full circle swing on ball bearing slew ring.

Equipped with manually locked/released swing brake.

Swing speed.....2.4 r/min.

HYDRAULIC SYSTEM

Pumps.....2 variable piston pumps for crane functions.

Tandem gear pump for steering, swing and optional equipments.

Control valves.....Multiple valves actuated by hand levers with integral pressure relief valves.

Circuit.....Equipped with air cooled type oil cooler.

Hydraulic oil tank

capacity.....approx. 740 liters

Filters.....Return line filter

CRANE CONTROL

By 5 control levers based on ISO standard layout.

CAB

Both crane and drive operations can be performed from one cab mounted on rotating superstructure.

One sided one-man type, steel construction with sliding door access and tinted safety glass windows opening at side, rear and roof.

Operator's 4 way adjustable seat with high back and seat belt.

TADANO Automatic Moment Limiter (Model: AML-L)

Main unit in crane cab gives audible and visual warning of approach to overload. Automatically cuts out crane motions before overload. With working range (working radius and/or boom angle and/or tip height) limit function.

Seven functions are constantly displayed.

Digital liquid crystal display:

Boom angle

Either boom length or potential hook height

Actual working radius

Actual hook load

Permissible load

Either jib offset angle or jib length

Boom position indicator

Outrigger position or on-tire indicator

Bar graphical display:

Either moment as percentage or main hydraulic pressure and torque converter oil pressure (Display changes by alternation key.)

OUTRIGGERS

4 hydraulically operated outriggers. Each outrigger controlled simultaneously or independently from the cab. Equipped with sight level gauge. Floats mounted integrally with the jacks retract to within vehicle width.

All cylinders fitted with pilot check valves.

Extended width

Fully.....7,200 mm

Middle.....6,700 mm

Middle.....5,500 mm

Float size (Diameter)..... 500 mm

COUNTERWEIGHT

Integral with swing frame

Mass.....5,500 kg

NOTE:

Each crane motion speed is based on unladen conditions.

CARRIER SPECIFICATIONS

SPEC. SHEET No. TR-500E-3-00101/EX-12

TYPE

Rear engine, left hand steering, driving axle 2-way selected type (by manual switch).

4 × 2 front drive

4 × 4 front and rear drive

FRAME

High-tensile steel, all welded mono-box construction.

ENGINE

Model.....MITSUBISHI 6D16-TLEA

Type.....4 cycle, turbo charged and after cooled, 6 cylinder in line, direct injection, water cooled diesel engine.

Piston displacement..... 7,545 cm³

Bore × stroke..... 118 mm × 115 mm

Max. output (SAE)..... Gross 184 kW {250 PS} at 2,800 r/min.

Max. torque (SAE)..... 706 N·m {72 kgf·m} at 1,400 r/min.

TRANSMISSION

Electronically controlled full automatic transmission. Torque converter driving full powershift with driving axle selector. 6 forward and 2 reverse speeds, constant mesh.

3 speeds-High range-2 wheel drive; 4 wheel drive

3 speeds-Low range-4 wheel drive

AXLES

Front..... Full floating type, steering and driving axle with planetary reduction.

Rear..... Full floating type, steering and driving axle with planetary reduction.
Non-spin differential.

STEERING

Hydraulic power steering controlled by steering wheel.

Three steering modes available:

2-wheel front

4-wheel coordinated

4-wheel crab

SUSPENSION

Front..... Rigid mounted to the frame.

Rear..... Pivot mounted with hydraulic lockout cylinders.

BRAKE SYSTEM

Service..... Air over hydraulic disc brakes on all 4 wheels.

Parking/

Emergency..... Spring applied-air released brake acting on input shaft of front axle.

Auxiliary..... Electro-pneumatic operated exhaust brake.

ELECTRIC SYSTEM

24 V DC. 2 batteries of 12 V-120 Ah capacity.

FUEL TANK CAPACITY

300 liters

TIRES

Front..... 29.5-25-22 PR(OR), Single × 2

Rear..... 29.5-25-22 PR(OR), Single × 2

TURN RADIUS

Min. turning radius (at center of extreme outer tire)

2-wheel steering..... 11.9 m

4-wheel steering..... 6.7 m

EQUIPMENTS

STANDARD EQUIPMENTS

Automatic moment limiter (AML-L)

External lamp (AML)

Pendant type over-winding cutout

Winch automatic fail-safe brake

Winch drum indicator (visual)

Cable follower

Winch drum mirror

Hook safety latch

Pilot check valves

Holding valves

Counterbalance valves

Hydraulic pressure relief valves

TADANO twin swing system

Swing brake

Swing lock

Boom angle indicator

Boom elevation foot pedal

Boom telescoping foot pedal

Sight level gauge

Hydraulic oil cooler

Electric windshield wiper and washer

Roof window wiper and washer

Roof window lock warning

Tachometer / Speedometer

Cloth covered cab seat with seat belt

Cab floor mats

Sun visor (Roof)

Neutral position adjustable control lever (swing and / or auxiliary winch)

Automatic drive system

Transmission neutral position start

Overshift prevention

Parking braked travel warning

Back-up alarm

Air cleaner dust indicator

Air dryer

Water separator with filter

Engine over-run alarm

Hydraulic lockout suspension

Non-spin differential (Rear)

Towing eyes – front and rear

OPTIONAL EQUIPMENTS

Electric fan

Cab heater and defroster (Diesel engine fuel oil)

Tire inflation kit

Cab cooler

Emergency steering

Hook block – 20 ton capacity (2 sheaves, swivel type with safety latch. Mass: 260 kg)

ON OUTRIGGERS

Unit : kg

Outriggers fully extended (7.2 m) 360° Rotation																
A \ B	11.0	15.0	19.0	23.0	27.0	31.0	35.0	C	9.8 m Jib				17.1 m Jib			
									5° offset		30° offset		5° offset		30° offset	
									B	W	B	W	B	W	B	W
3.0	50,000	41,200	37,200													
3.5	50,000	41,200	37,200	21,500				80°	7.8	5,600	11.2	2,800	9.7	2,800	15.9	1,100
4.0	48,400	41,200	35,500	21,500				75°	12.0	5,000	15.0	2,500	14.4	2,300	20.3	1,000
4.5	43,800	41,200	33,000	21,500	21,500			70°	15.8	4,000	18.7	2,300	18.9	1,900	24.4	900
5.0	39,800	38,900	31,500	21,500	21,000			65°	19.4	3,200	22.2	2,150	23.2	1,600	28.2	850
5.5	36,900	36,200	30,200	21,500	20,400			60°	22.9	2,600	25.4	2,000	27.2	1,400	31.8	800
6.0	33,900	33,300	28,800	21,500	19,900			55°	26.1	2,150	28.4	1,750	31.0	1,200	35.1	750
6.5	31,000	30,800	27,600	21,000	19,100	15,300		50°	29.1	1,650	31.1	1,450	34.6	1,050	38.1	700
7.0	28,800	28,600	26,400	20,500	18,300	14,800		45°	31.8	1,100	33.6	1,050	37.8	800	40.8	650
8.0	23,700	24,600	23,100	19,000	16,700	13,800	12,700	40°	34.3	700	35.7	650				
9.0	16,200	19,000	18,700	17,200	15,100	12,600	11,700									
10.0		15,300	15,100	15,600	13,800	11,700	10,800									
11.0		12,600	12,600	13,200	12,600	10,800	9,900									
12.0		10,500	10,600	11,200	11,500	10,000	9,100									
13.0			8,800	9,600	10,000	9,300	8,400									
14.0			7,600	8,300	8,800	8,600	7,800									
15.0			6,400	7,200	7,700	8,100	7,300									
16.0			5,500	6,200	6,700	7,100	6,800									
17.0			4,700	5,400	5,900	6,300	6,400									
18.0				4,700	5,200	5,600	5,700									
19.0				4,100	4,600	4,900	5,100									
20.0				3,600	4,000	4,400	4,600									
22.0					3,100	3,400	3,600									
24.0						2,400	2,900									
26.0							2,100	2,300								
28.0								1,600	1,900							
30.0									1,500							
32.0										1,100						
32.9											1,000					
D				0°												

A : Boom length (m)
 B : Load radius (m)
 C : Boom angle
 D : Minimum boom angle for indicated length (without load)
 W : Rated lifting capacity

Unit : kg

Outriggers extended to middle (6.7 m) Over side																
A \ B	11.0	15.0	19.0	23.0	27.0	31.0	35.0	C	9.8 m Jib				17.1 m Jib			
									5° offset		30° offset		5° offset		30° offset	
									B	W	B	W	B	W	B	W
3.0	50,000	41,200	37,200													
3.5	50,000	41,200	37,200	21,500				80°	7.8	5,600	11.2	2,800	9.7	2,800	15.9	1,100
4.0	48,400	41,200	35,500	21,500				75°	12.0	5,000	15.0	2,500	14.4	2,300	20.3	1,000
4.5	43,800	41,200	33,000	21,500	21,500			70°	15.8	4,000	18.7	2,300	18.9	1,900	24.4	900
5.0	39,800	38,900	31,500	21,500	21,000			65°	19.4	3,200	22.2	2,150	23.2	1,600	28.2	850
5.5	36,900	36,200	30,200	21,500	20,400			60°	22.9	2,600	25.4	2,000	27.2	1,400	31.8	800
6.0	33,900	33,300	28,800	21,500	19,900			55°	26.0	1,800	28.4	1,750	31.0	1,200	35.1	750
6.5	31,000	30,800	27,600	21,000	19,100	15,300		50°	29.0	1,350	31.0	1,150	34.6	1,000	38.1	700
7.0	28,800	27,100	26,400	20,500	18,300	14,800		45°	31.7	850	33.5	750	37.7	550	40.7	500
8.0	20,000	20,100	20,000	19,000	16,700	13,800	12,700									
9.0	15,900	16,000	16,000	17,200	15,100	12,600	11,700									
10.0		13,200	13,100	14,000	13,800	11,700	10,800									
11.0		11,100	10,900	11,700	12,100	10,800	9,900									
12.0		9,400	9,200	9,800	10,300	10,000	9,100									
13.0			7,800	8,400	8,600	8,900	8,400									
14.0			6,600	7,200	7,600	7,900	7,800									
15.0			5,600	6,200	6,700	7,100	6,800									
16.0			4,800	5,400	5,900	6,100	6,000									
17.0			4,000	4,600	5,200	5,400	5,300									
18.0				4,000	4,600	4,800	4,600									
19.0				3,500	4,000	4,200	4,100									
20.0				3,000	3,500	3,700	3,700									
22.0					2,700	2,900	2,900									
24.0					2,000	2,200	2,300									
26.0						1,600	1,800									
28.0							1,100	1,400								
30.0								1,000								
32.0									700							
D				0°				7°								

ON OUTRIGGERS

Unit : kg

		Outriggers extended to middle (5.5 m)						Over side									
B	A	11.0	15.0	19.0	23.0	27.0	31.0	35.0	C	9.8 m Jib				17.1 m Jib			
										5° offset		30° offset		5° offset		30° offset	
		B		W		B		W		B		W					
3.0		50,000	41,200	37,200													
3.5		50,000	41,200	37,200	21,500				80°	7.8	5,600	11.2	2,800	9.7	2,800	15.9	1,100
4.0		48,400	41,200	35,500	21,500				75°	12.0	5,000	15.0	2,500	14.4	2,300	20.3	1,000
4.5		43,800	41,200	33,000	21,500	21,500			70°	15.8	4,000	18.7	2,300	18.9	1,900	24.4	900
5.0		39,800	38,900	31,500	21,500	21,000			65°	19.4	3,100	22.2	2,150	23.2	1,600	28.2	850
5.5		36,900	36,200	30,200	21,500	20,400			60°	22.7	1,850	25.3	1,600	27.2	1,400	31.8	800
6.0		29,700	25,700	25,900	21,500	19,900			55°	25.9	1,100	28.2	900	30.9	750	35.1	550
6.5		24,200	22,000	21,600	21,000	19,100	15,300		50°	28.9	500						
7.0		20,500	19,600	18,700	19,800	18,300	14,800										
8.0		15,600	15,400	15,300	15,600	16,200	13,800	12,700									
9.0		12,300	12,200	11,900	12,600	13,000	12,600	11,700									
10.0			9,900	9,500	10,400	10,800	11,200	10,800									
11.0			8,100	7,800	8,400	9,300	9,500	9,700									
12.0			6,700	6,400	7,000	7,700	8,100	8,300									
13.0				5,300	6,000	6,600	6,900	7,000									
14.0				4,400	5,100	5,600	6,000	6,200									
15.0				3,700	4,300	4,800	5,200	5,300									
16.0				3,000	3,600	4,100	4,500	4,700									
17.0				2,500	3,100	3,500	3,900	4,100									
18.0					2,600	3,000	3,300	3,600									
19.0					2,200	2,600	2,800	3,100									
20.0					1,800	2,200	2,400	2,600									
22.0						1,500	1,700	1,900									
24.0						1,000	1,200	1,400									
26.0							700	900									
28.0								500									
D				0°					23°								
									33°								

- A : Boom length (m)
- B : Load radius (m)
- C : Boom angle
- D : Minimum boom angle for indicated length (without load)
- W : Rated lifting capacity

NOTES FOR "ON OUTRIGGERS" TABLE

- Rated lifting capacities shown in the table are based on condition that crane is set on firm level surface. Those above bold lines are based on crane strength and those below, on its stability.
- Rated lifting capacities based on crane stability are according to ISO 4305.
- The mass of the hook (500 kg for 50 ton capacity, 150 kg for 5.6 ton capacity), slings and all similarly used load handling devices must be added to the weight of the load.
- For rated lifting capacity of single top, reduce the 500 kg from the relevant boom rated lifting capacity. Rated lifting capacity of single top should not exceed 5,600 kg.
- Standard number of parts of line for each boom length is as shown below. Load per line should not surpass 52.9 kN {5,400 kgf} for main winch and 54.9 kN {5,600 kgf} for auxiliary winch.

Boom length (m)	11.0	15.0	19.0	23.0	27.0	31.0	35.0	Jib / Single top
No. of parts of line	10	8	8	4	4	4	4	1

The lifting capacity data stored in the AUTOMATIC MOMENT LIMITER (AML-L) is based on the standard number of parts of line listed in the chart.

Maximum lifting capacity is restricted by the number of parts of line of AUTOMATIC MOMENT LIMITER (AML-L).

- The over-side rated lifting capacity depends on outrigger extension. Rated lifting capacity of over-front and over-rear assume fully extended outrigger position. Working area for each outrigger position are given separately and must be followed accordingly during operation.

Outriggers position	Extended to middle (6.7 m)	Extended to middle (5.5 m)
Angle a°	30	25

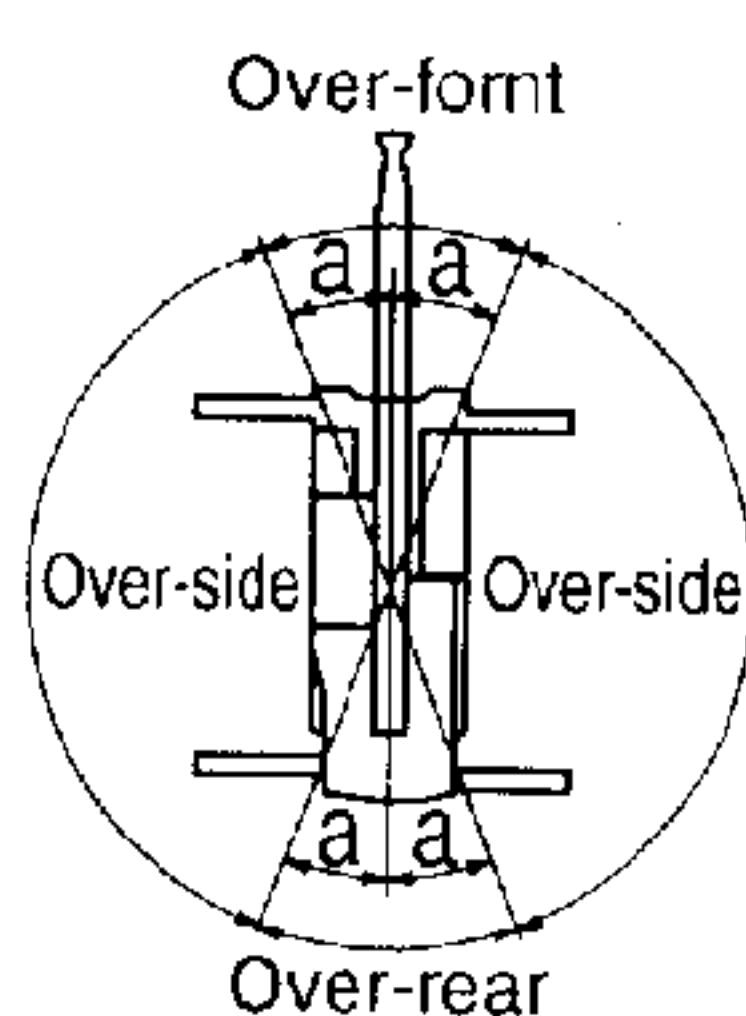

ON TIRES

Unit : kg

A B	Stationary						Creep					
	Over front			360°			Over front			360°		
	11.0m	19.0m	27.0m	11.0m	19.0m	27.0m	11.0m	19.0m	27.0m	11.0m	19.0m	27.0m
3.0m	31,000			15,600			23,000					
3.5m	27,800			15,000			21,300			12,900		
4.0m	25,400			12,900			19,700			10,900		
4.5m	23,500	15,400		10,600	10,200		18,300	14,000		9,300	9,000	
5.0m	22,000	14,900		9,000	8,600		16,900	13,300		7,800	7,500	
5.5m	19,100	14,300		7,600	7,300		15,600	12,700		6,600	6,400	
6.0m	16,800	13,500	9,400	6,600	6,200	6,700	14,400	12,100	8,300	5,700	5,500	5,900
6.5m	14,600	12,900	9,400	5,600	5,400	5,800	12,800	11,600	8,300	4,900	4,700	5,000
7.0m	12,800	11,700	9,400	4,900	4,600	5,100	11,300	10,300	8,300	4,200	3,900	4,400
8.0m	10,000	9,100	9,100	3,500	3,300	3,900	8,900	7,900	8,100	3,000	2,800	3,400
9.0m	8,100	7,200	7,700	2,500	2,400	2,900	7,100	6,300	6,800	2,000	1,800	2,600
10.0m		5,900	6,500		1,600	2,200		5,200	5,800		1,300	1,900
11.0m		4,800	5,600		1,000	1,500		4,200	4,900		800	1,400
12.0m		3,900	4,700			1,000		3,500	4,200			800
13.0m		3,200	4,000			600		2,800	3,500			500
14.0m		2,500	3,400					2,200	3,000			
15.0m		2,000	2,900					1,800	2,500			
16.0m		1,500	2,400					1,400	2,100			
17.0m		1,000	2,000					900	1,700			
18.0m			1,700						1,400			
19.0m			1,300						1,100			
20.0m			1,000						900			
22.0m			600						500			
C		0°	27°	0°	46°	58°		0°	29°	0°	47°	58°

A: Boom length B: Load radius C: Minimum boom angle for indicated length (without load)

WORKING AREA

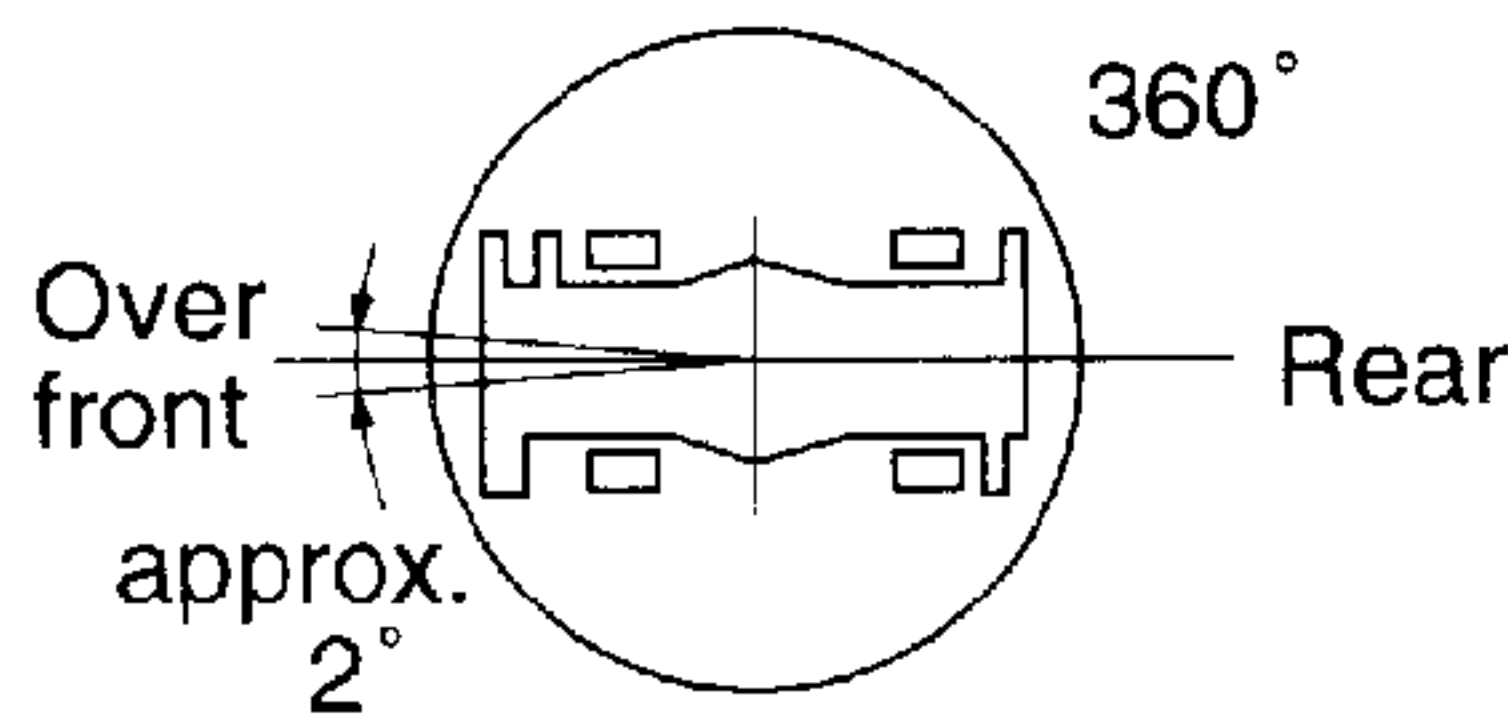

Without outriggers "Over front" operation should be performed within 2 degrees in front of chassis.

NOTES FOR "ON TIRES" TABLES

- Rated lifting capacities shown in the table are based on condition that crane is set on firm level surface, with suspension lock applied. Those above bold lines are based on tire capacity and those below, on crane stability. They are based on actual working radii increased by tire deformation and boom deflection.
- Rated lifting capacities based on crane stability are according to ISO 4305. "STATIONARY" load capacities do not exceed 75 % of tipping load. "CREEP" load capacities do not exceed 66 2/3 % of tipping load.
- The mass of the hook (500 kg for 50 ton capacity, 150 kg for 5.6 ton capacity), slings and all similarly used load handling devices must be added to the weight of the load.
- For rated lifting capacity of single top, reduce the 500 kg from the relevant boom rated lifting capacity. Rated lifting capacity of single top should not exceed 5,600 kg.
- Without outriggers lifting with "jib" is not permitted. Maximum permissible boom length is 27.0 m.
- CREEP is motion for crane not to travel more than 60 m in any 30 min. period and to travel at the speed of less than 1.6 km/h.
- During "CREEP" duties travel slowly and keep the lifting load as close to the ground as possible, and especially avoid any abrupt steering, accelerating or braking.
- Do not operate the crane while carrying the load.
- Tires should be inflated to their correct air pressure of 412 kPa {4.2 kgf/cm²}.
- For CREEP operation, set Drive select switch to "4-WHEEL(Lo)" and set gear shift lever to "1".
- Standard number of parts of line for on tires operation should be according to the following table.

Boom length (m)	11.0	19.0	27.0
No. of parts of line	6	4	4

The lifting capacity data stored in the AUTOMATIC MOMENT LIMITER (AML-L) is based on the standard number of parts of line listed in the chart.

Boom Length

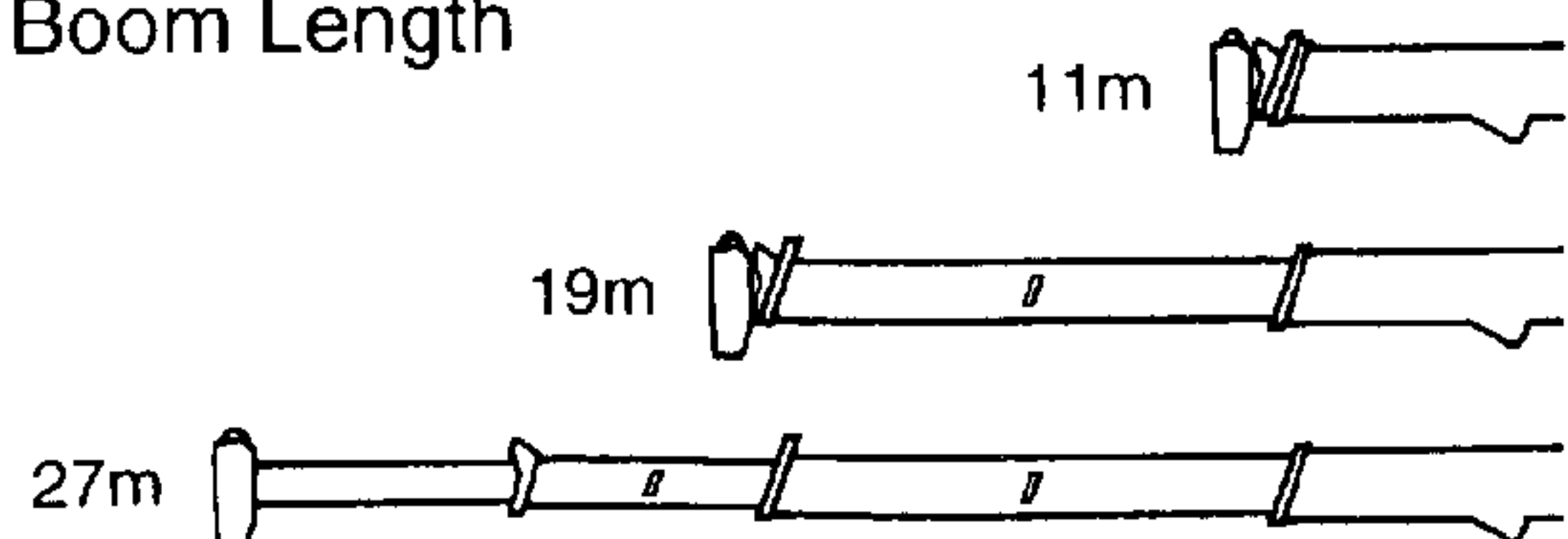

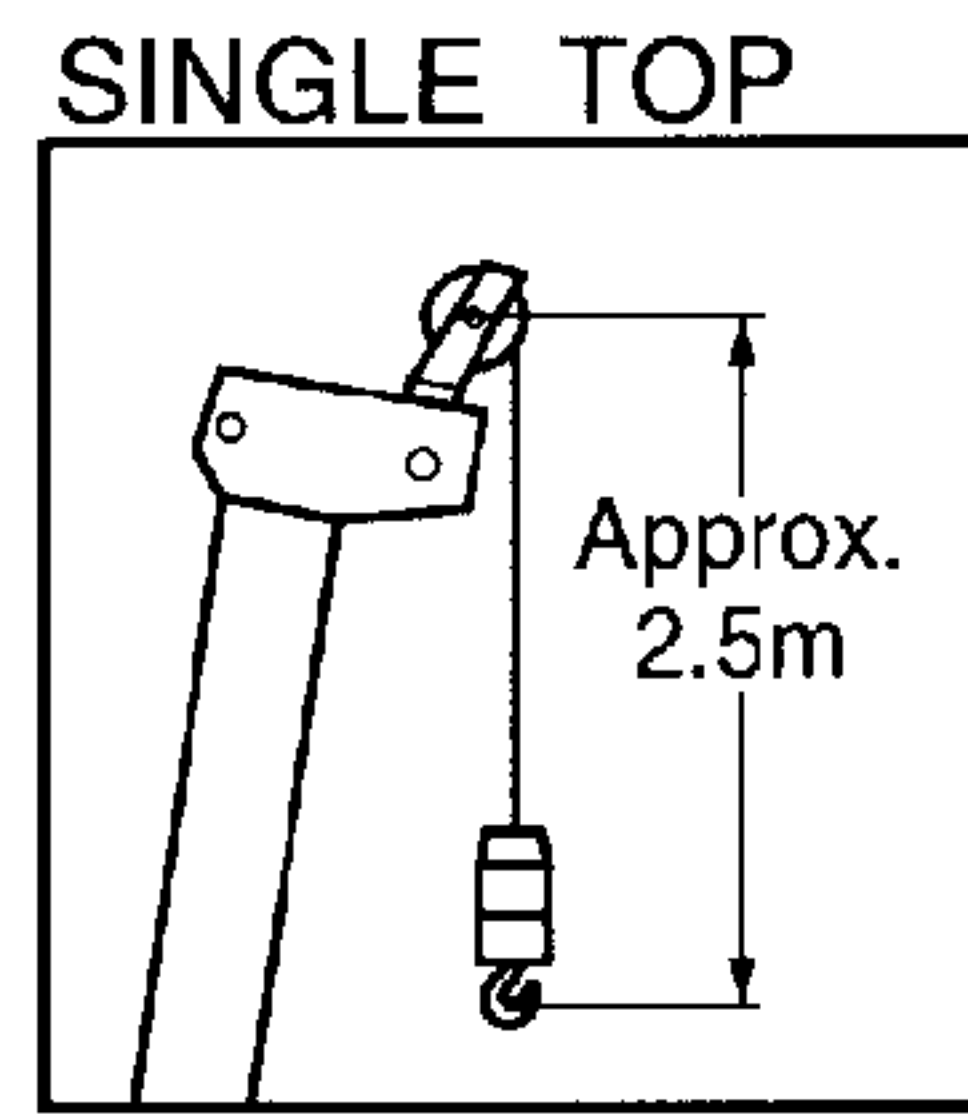
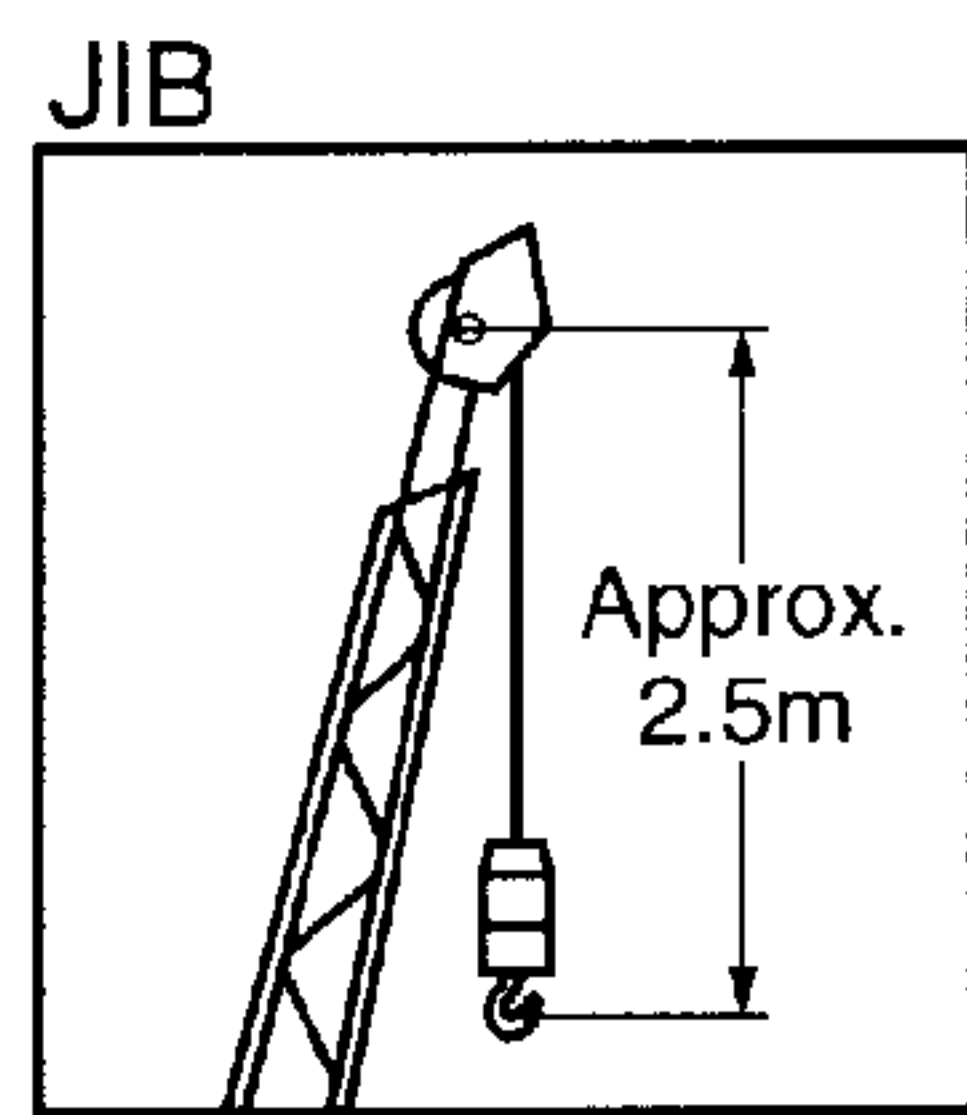
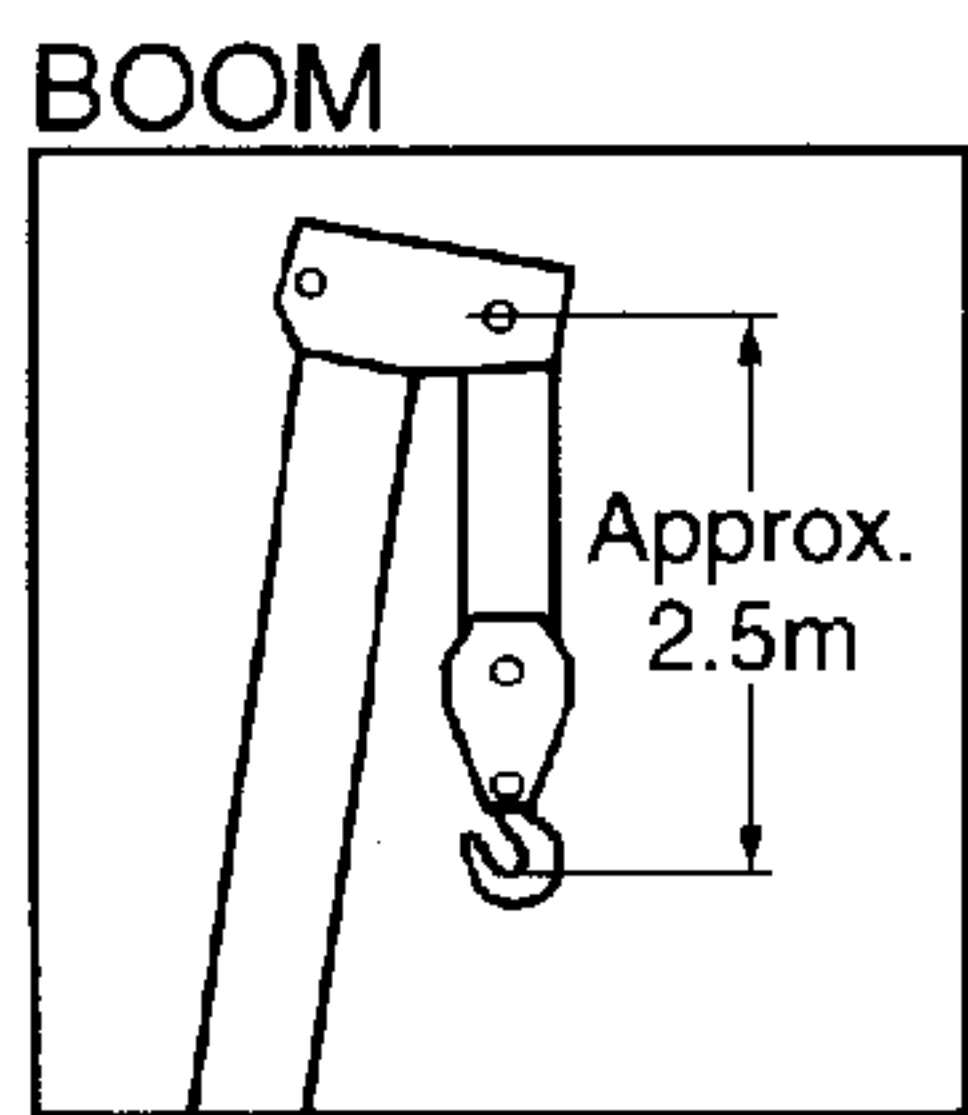
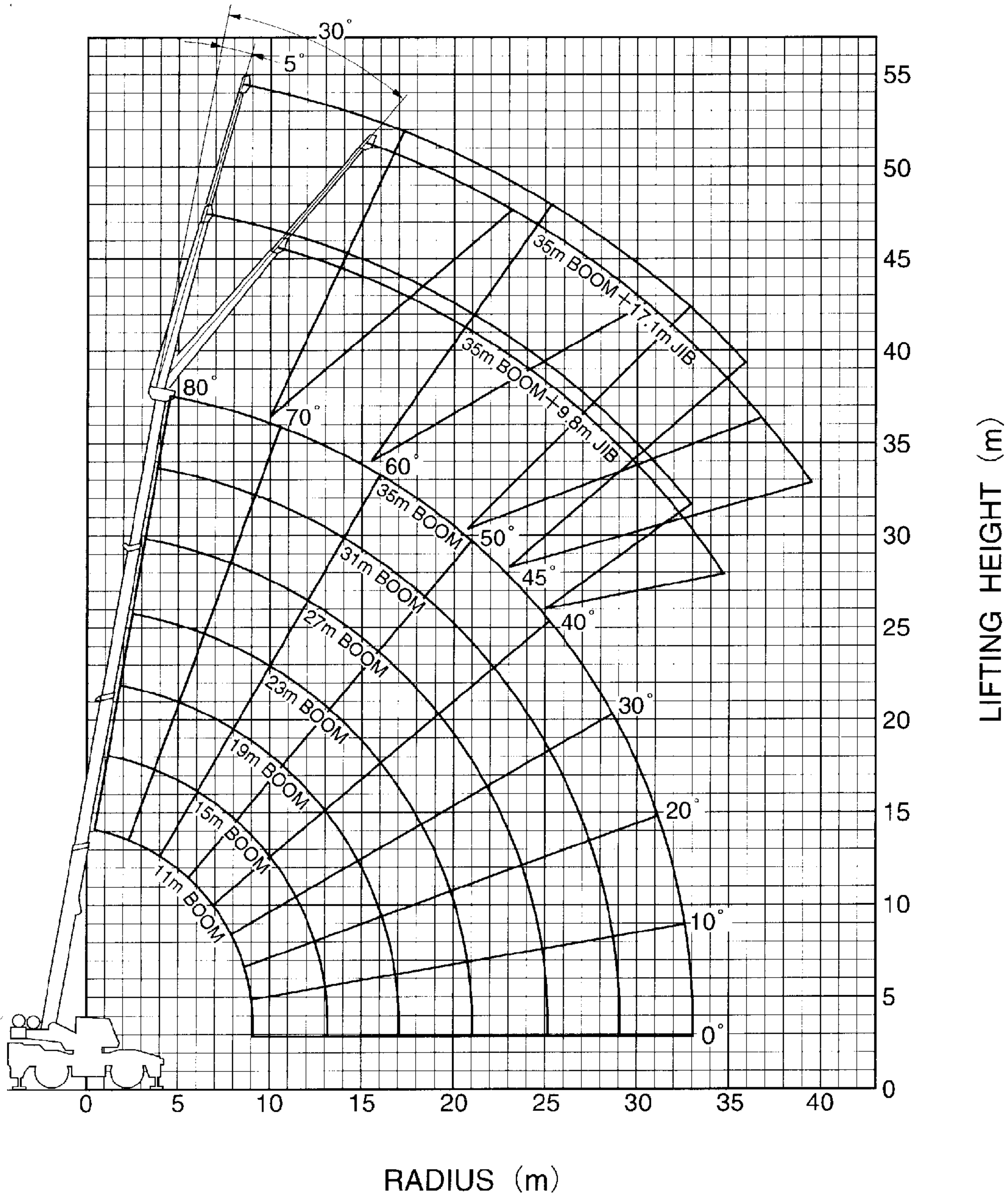

NOTE:

The above lifting height and boom angle are based on a straight (unladen) boom, and allowance should be made for boom deflection obtained under laden conditions.

DIMENSIONS

SPEC. SHEET No. TR-500E-3-00101/EX-12

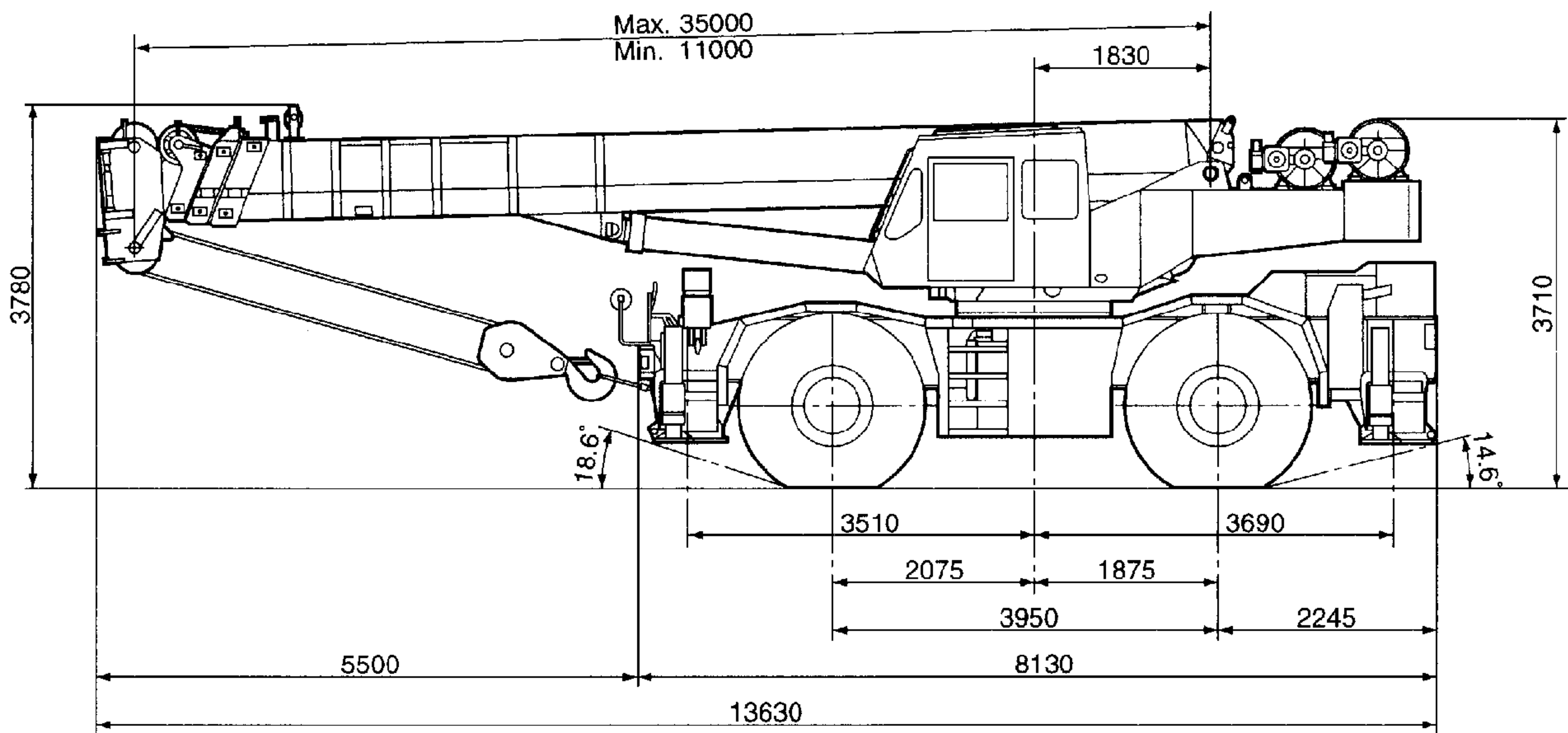

Overall width 3,315 mm
 Tail swing radius 4,120 mm

Tread (track) – Front 2,502 mm
 – Rear 2,502 mm

NOTE:

Dimension is with boom angle at -1.5° .

Specifications are subject to change without notice.



TADANO

TADANO LTD.

4-12, Kamezawa 2-chome,
 Sumida-ku, Tokyo 130-0014, Japan
 Tel: (03)3621-7750
 Telex: J23755 TADANO
 Fax: (03)3621-7785
 Cable: TADANIRCO TOKYO

Printed in Japan RKK-1